

OV9724 720p HD product brief



Compact, High Performance 720p HD Image Sensor for Smartphones, Ultra-Thin Notebooks and Tablets



available in
a lead-free
package

OmniVision's OV9724 is a compact, high performance image sensor offering 720p high definition video capture at 30 frames per second (fps) in an industry-leading miniaturized form factor. The low-power 1/9-inch OV9724 CameraChip™ sensor is built on OmniVision's powerful 1.4-micron OmniBSI+™ pixel architecture, enabling high quality color images and fast frame 720p HD video at 30 fps or cropped VGA at 60 fps on a highly-compact camera modules of 6 x 4.5 x 2.5 mm.

This unprecedented combination of high performance and small form factor allows HD cameras to be integrated into ultra-slim, narrow-bezel devices, making it an attractive solution for next-generation smartphones, notebooks, tablets, portable gaming

systems and other mobile devices. The OV9724 is designed to satisfy all major industry standard performance and quality requirements currently prevailing in the market, offering customers an extensive flexibility when designing advanced imaging systems.

The OV9724 provides full-frame, sub-sampled or windowed 10-bit images. All required image processing functions, including exposure control and defective pixel cancelling, are programmable through the serial camera control bus (SCCB) interface. The image sensor is available in COB and CSP3 versions and features a one-lane, high-speed MIPI interface.

Find out more at www.ovt.com.

Applications

- PC Multimedia
- Smartphones
- Tablets
- Handheld Devices
- Games

Product Features

- MIPI and D-PHY specification (contains one clock lane and one data lane) with a maximum of 400 Mbps data transfer rate
- low operating voltage and low power consumption for embedded portable applications
- high sensitivity and low dark current for low-light conditions
- supports global analog gain
- supports free-running clock and gated clock
- supports down sample mode and VarioPixel[®]
- auto black level calibration
- defect correction capability

OV9724

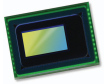

Ordering Information

- **OV09724-A28A**
(color, lead-free, 28-pin CSP3)
- **OV09724-G04A**
(color, chip probing, 200 μm backgrinding, reconstructed wafer)

Product Specifications

- **active array size:** 1280 x 720
- **power supply:**
 - core: 1.5V
 - analog: 2.8V
 - I/O: 1.8V
- **power requirements:**
 - active: 55 mA
 - hardware standby: 60 μA
 - XSHUTDOWN: 20 μA
- **temperature range:**
 - operating: -30°C to 70°C junction temperature
 - stable image: 0°C to 50°C junction temperature
- **output formats:** 10-bit raw RGB data
- **lens size:** 1/9"
- **lens chief ray angle:** 30.1° non-linear
- **input clock frequency:** 6 - 27 MHz
- **max S/N ratio:** 36.2 dB
- **dynamic range:** 70.4 dB @ 8x gain
- **maximum image transfer rate:** 30 fps
- **sensitivity:** 740 mV/lux-sec
- **scan mode:** progressive
- **maximum exposure interval:** 760 x t_{ROW}
- **pixel size:** 1.4 μm x 1.4 μm
- **dark current:** 8 mV/s @ 50°C junction temperature
- **image area:** 1840 μm x 1040 μm
- **package/die dimensions:**
 - CSP3: 3850 μm x 2810 μm
 - COB: 3840 μm x 2800 μm

Functional Block Diagram

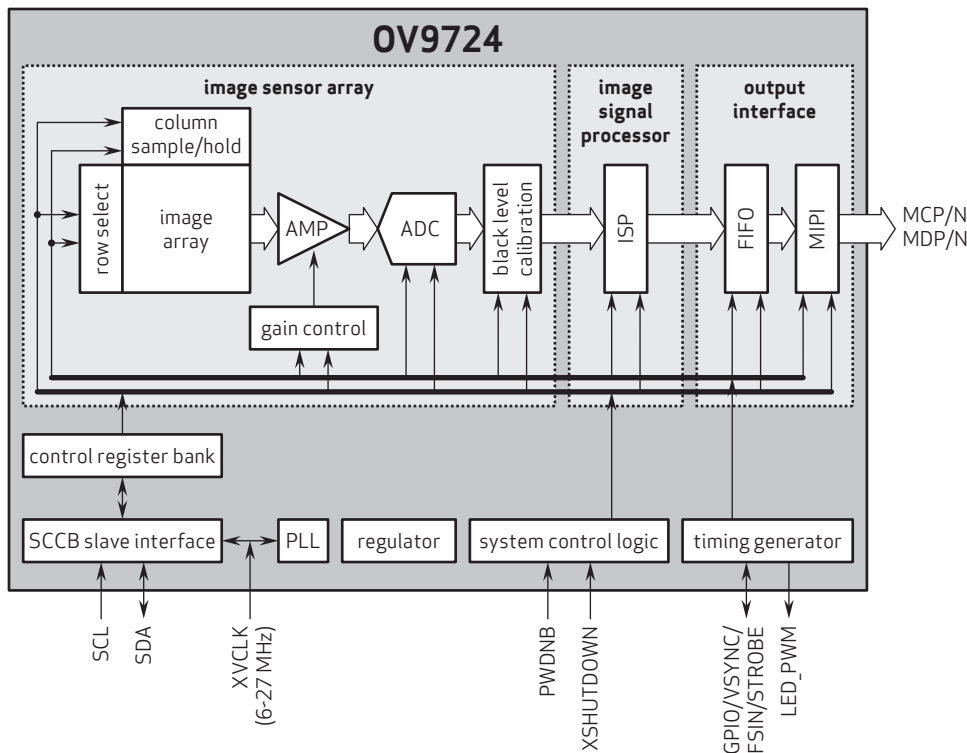

4275 Burton Drive
Santa Clara, CA 95054
USA

Tel: +1 408 567 3000
Fax: +1 408 567 3001
www.ovt.com

OmniVision reserves the right to make changes to their products or to discontinue any product or service without further notice. OmniVision and VarioPixel are registered trademarks of OmniVision Technologies, Inc. The OmniVision logo and OmniBSI are trademarks of OmniVision Technologies, Inc. All other trademarks are the property of their respective owners.