

DATASHEET

GYPRO2300 MEMS Angular rate sensor

Doc Ref: DSG2300
Rev: 2.2
Date: Sept 2016

Key features

- Digital angular rate sensor with SPI interface
- Angular rate measurement around Z-axis (yaw)
- $\pm 300^\circ/\text{sec}$ input range
- Ultra-Low Noise
- Excellent bias instability
- 24-bit angular rate output
- Digital temperature output
- Factory calibrated and temperature compensated angular rate output over -40°C to $+85^\circ\text{C}$
- Built-in continuous self-test available on external pin
- Single supply voltage: from 4.75 V to 5.25 V
- Low current consumption in operation: 25 mA
- CLCC 30 package: 19.6 mm x 11.5 mm x 2.9 mm

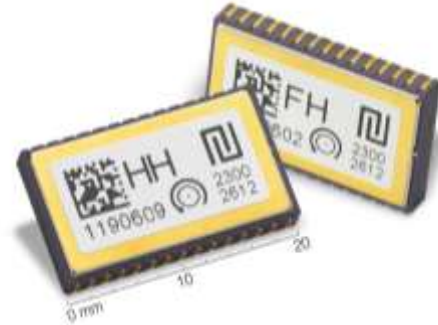

Applications

- Precision instrumentation
- Platform stabilization and control
- Unmanned vehicles
- GPS assistance

General description

GYPRO[®] product line is a new generation of Micro-Electro-Mechanical Systems (MEMS) angular rate sensor specifically designed for demanding applications.

The sensor consists of a MEMS transducer and an integrated circuit (IC) packaged in a 30-pin Ceramic Leadless Chip carrier (CLCC) package.

This MEMS transducer is manufactured using Tronics proprietary vacuum wafer-level packaging technology based on micro-machined thick single crystal silicon.

The IC provides a stable primary anti-phase vibration of the 'drive' proof masses, thanks to electrostatic comb drives. When the sensor is subjected to a rotation, the Coriolis force acts on the 'sense' proof masses and forces them into a secondary anti-phase movement perpendicular to the direction of drive vibration, which is itself counter-balanced by electrostatic forces. The sense closed loop operates as an electromechanical $\Sigma\Delta$ modulator providing a digital output. This output is finally demodulated using the drive reference signal.

The sensor is factory calibrated and compensated for temperature effects to provide high-accuracy digital output over a broad temperature range.

Tronic's Microsystems S.A.

98 rue du Pré de l'Horme, 38920 Crolles, France
Phone: +33 (0)4 76 97 29 50 Fax +33 (0)4 76 97 29 51
www.tronicsgroup.com

internal reference : MCD001-A

1/41

- PROPRIETARY -

Ordering information

Part number	Description	Latency (ms)	Data rate (Hz)	Package
GYPRO2300	Standard configuration	40	200	CLCC30
GYPRO2300LD	Low-delay configuration	2	1600	CLCC30

The Low-Delay configuration, called GYPRO2300LD, enables reducing the latency and increasing the data rate of the sensor.

As a consequence, the user has to implement its own filtering in order to limit the bandwidth down to 100Hz (or below) and to obtain the same performances as the standard configuration.

Information furnished by Tronics is believed to be accurate and reliable. However, no responsibility is assumed by Tronics for its use, nor for any infringements of patents or other rights of third parties that may result from its use.

Specifications subject to change without notice.

No license is granted by implication or otherwise under any patent or patent rights of Tronics. Trademarks and registered trademarks are the property of their respective owners.

Contents

Key features	1
Applications	1
General description	1
Ordering information	2
Contents	3
1 Block diagram	5
2 Package: axial orientation and outline dimensions	7
3 Pin configuration and function descriptions	8
4 Application circuit	9
4.1 Power supply	9
4.2 Power management	9
4.3 Filtering	9
4.4 SPI interface	9
4.5 Self-test	9
5 Soldering guidelines	11
5.1 Reflow profile	11
5.2 PCB Footprint	12
6 Specifications	13
6.1 Mechanical Characteristics	13
6.2 Electrical characteristics	16
6.3 Environmental conditions	16
6.4 Maximum ratings	17
6.5 ESD caution	17
7 Typical performance characteristics	18
8 Temperature-compensation procedure for the angular rate output	21
8.1 Purpose	21
8.2 Algorithm overview	21
8.3 Procedure	22
8.4 Typical Walkthrough	23
9 Calibration procedure for the temperature sensor	24
9.1 Purpose	24
9.2 Algorithm overview	24
9.3 Procedure	24
9.4 Typical Walkthrough	25
10 Digital Interface	26
10.1 Electrical characteristics	26
10.2 Timing parameters	27
10.3 SPI recommendations	28

DATASHEET
GYPRO2300

11	Registers and SPI frames	29
11.1	Clock System.....	29
11.2	SPI Register	30
11.3	Output Data	31
11.4	Device Configuration	32
11.5	Device Identification	39
12	Document change control	40

1 Block diagram

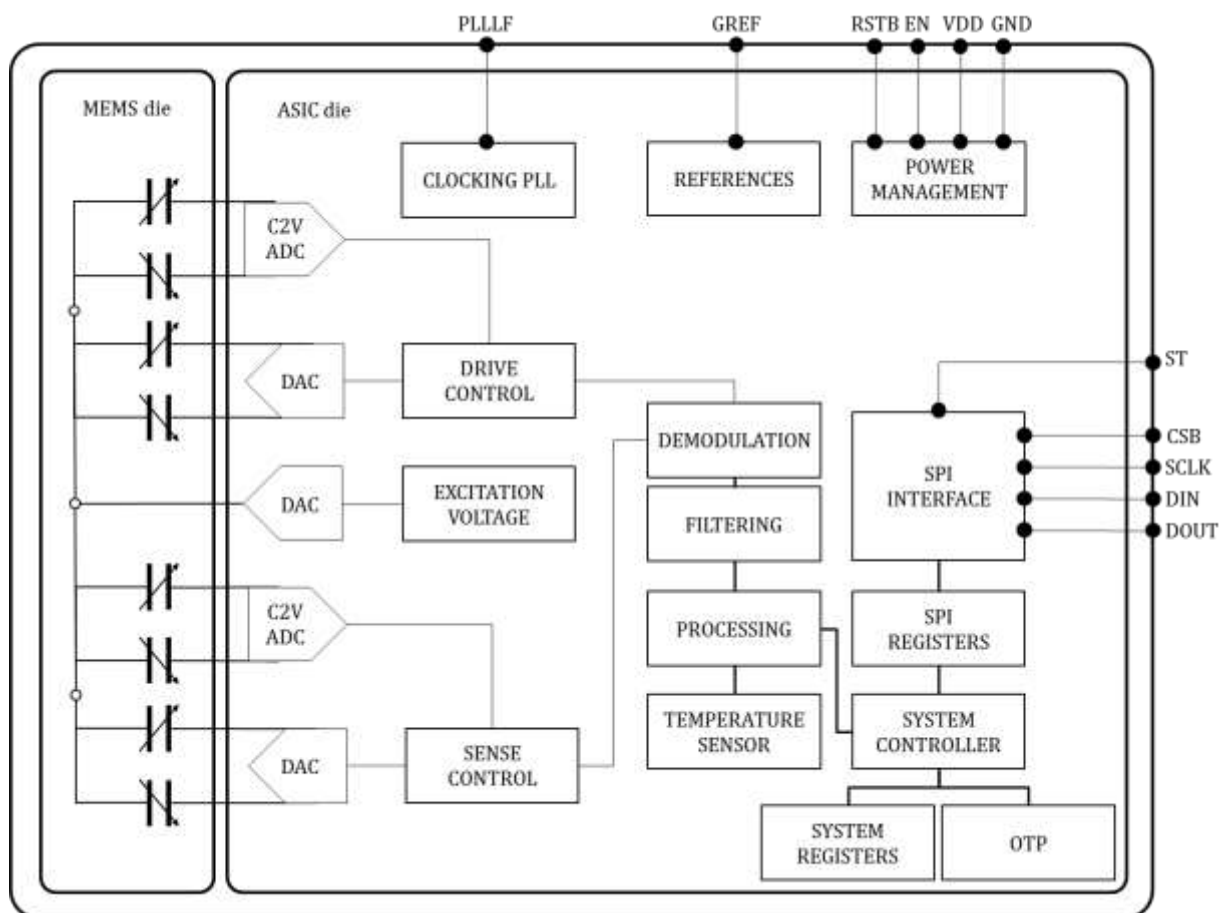

Figure 1: GYPRO2300 sensor block diagram

The sensing element (MEMS die) is located on the left part of the diagram. The MEMS consists of two coupled sub-structures subjected to linear anti-phase vibrations. The structures are vacuumed at the wafer level providing high Q-factor in the drive mode. The drive system is decoupled from the sense system in order to reduce feedback from sense motion to drive electrodes. The drive anti-phase vibration is sustained by electrostatic comb drives. The sense anti-phase vibration resulting from Coriolis forces is counter-balanced by electrostatic forces. Differential detection and actuation are used for both drive and sense systems and for each sub-structure, keeping two identical structures for efficient common mode rejection.

The integrated circuit (IC) is located on the right part of the diagram. The IC is designed to interface the MEMS sensing element. It includes ultra-low noise capacitive to voltage converters (C2V) followed by high-resolution voltage digitization (ADC) for both drive and sense paths. Excitation voltage required for capacitance sensing circuits is generated on the common electrode node. 1-bit force feedbacks (DAC) are used for both drive and sense system actuation.

The digital part implements digital drive and sense loops, demodulates, decimates and processes the gyro output based on the on-chip temperature sensor output. The system controller manages the interface between the SPI registers, the system register and the non-volatile memory (OTP). The non-volatile memory provides the gyro settings, in particular the coefficients for angular rate sensor temperature compensation. On power up, the gyro settings are transferred from the OTP to the system registers and output data are available in the SPI registers. The angular rate sensor output and the temperature sensor output are available in the SPI registers. The SPI registers are available through the SPI interface (CSB, SCLK, DIN, DOUT). The self-test is available on the external pin ST.

The "Clocking PLL" block locks the system clock to the sensor drive frequency and generates the master clock of the system. An external filtering is required on the pin PLLLF.

The "References" block generates the required biasing currents and voltages for all blocks, the low-noise reference voltage for critical blocks as well as the high voltage required for improved start-up time (through an integrated charge pump). An external filtering for the low-noise reference voltage is required on the pin GREF.

The "Power Management" block manages the power supply of the sensor from a single 5V supply between the VDD and GND pins. It includes a power on reset as well as an external reset pin (RSTB) to start or restart operation using default configuration. An enable pin (EN) with power-down capability is also available.

2 Package: axial orientation and outline dimensions

The sensitive rate axis is perpendicular to the package. The sensor marking includes not only the rate axis direction but also the relevant information for a full traceability of the product (see details in paragraph 11.5). A data matrix marking is provided for automated identification.

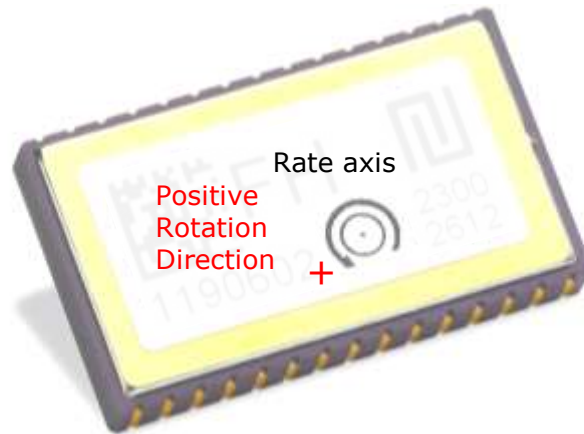
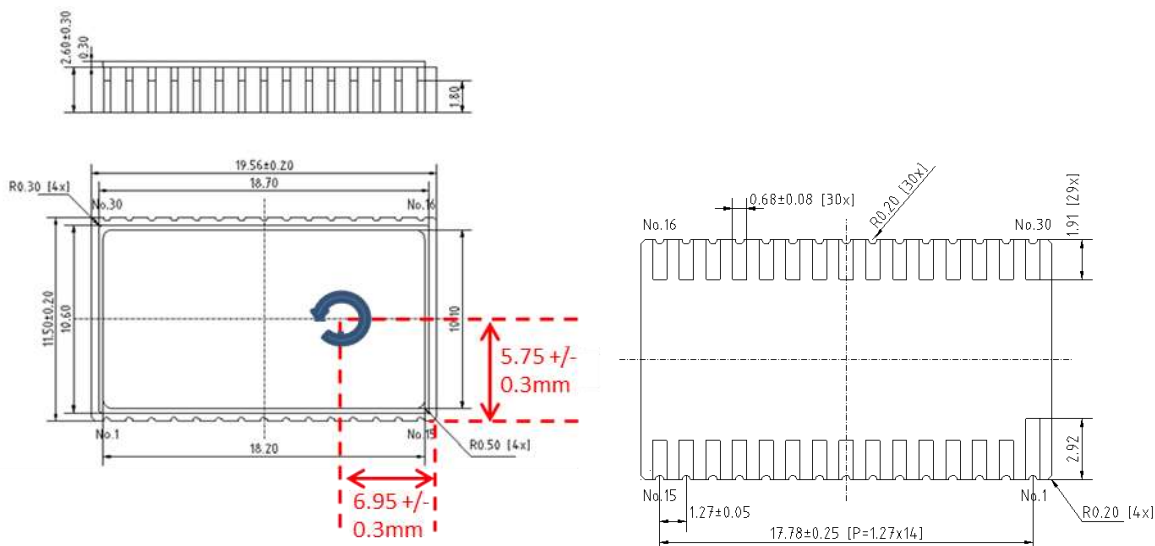

Figure 2: Axial orientation (Top side facing up with marking)

The package is a 30-pins Ceramic Leadless Chip Carrier (CLCC) with dimensions of 19.56 mm x 11.50 mm x 2.90 mm (including the package lid). The sensor is compliant with Restrictions on Hazardous Substances (RoHS), having lead-free terminations. Solder terminations finish is 1.5µm Gold (min) over 2µm Nickel (min).



**Figure 3: Outline dimensions including the package lid (shown in millimeters).
Proof mass center is located at the center of the circular arrow**

3 Pin configuration and function descriptions

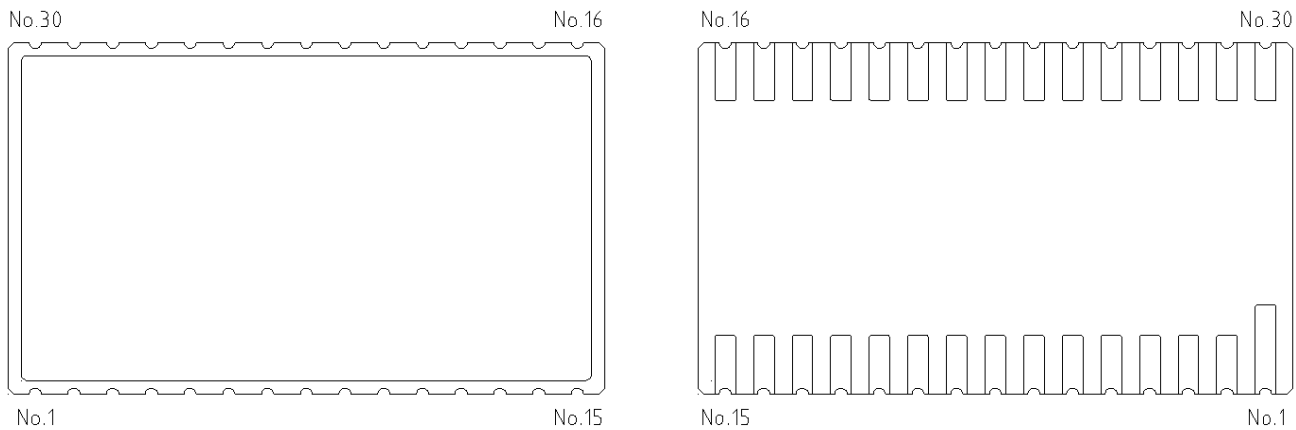

Figure 4: Top (left) and bottom (right) side views of the package showing pin assignments

Pin No.	Mnemonic	Type ^(*)	Description
1,2,3	GND	S	Power ground.
4	REF	F	Voltage reference buffer.
5	DNC	N/A	Do not connect.
6	EN	I	Chip enable (Active high).
7	DNC	N/A	Do not connect.
8	VDD	S	Power supply.
9	GND	S	Power ground.
10	VDD	S	Power supply.
11	PLLLF	F	PLL loop filter.
12,13,14	DNC	N/A	Do not connect.
15	ST	O	Self-test.
16	RSTB	I	Reset (Active low).
17,18,19	DNC	N/A	Do not connect.
20	CSB	I	SPI chip select (Active low).
21	SCLK	I	SPI serial clock.
22	DIN	I	SPI data input.
23	DOUT	O	SPI data output.
24	DNC	N/A	Do not connect.
25	VDD	S	Power supply.
26	GND	S	Power ground.
27	CLCK400	O	Internal clock.
28,29,30	GND	S	Power ground.

Table 1 : Pin function descriptions

(*) The pin type is defined as follows:

“S” is Supply, “O” is Output, “I” is Input, “F” is Filtering and “N/A” is Not Applicable. The section 4 describes the pin function in more details.

4 Application circuit

4.1 Power supply

The sensor is powered with a single 5V DC power supply through pins VDD and GND.

Although the sensor contains three separate VDD pins, the sensor is supplied by a single 5V voltage source. It is recommended to supply the three VDD pins in a star connection with appropriate decoupling capacitors, a 100nF decoupling capacitor close to the 5V supply input and a 100pF decoupling capacitor as close as possible to each VDD pins. Regarding the sensor grounds, all the GND pins are internally shorted. The GND pins redundancy is used for multiple bonds in order to reduce the total ground inductance. It is therefore recommended to connect all the GND pins to the ground.

4.2 Power management

The digital interface operates at 5V logic levels (VDD high, GND low levels).

To operate in normal mode, the EN pin needs to be connected to VDD (high level). The SPI interface can be used 1 ms after enabling the sensor (to allow completion of the digital part startup sequence). The sensor can be powered down in order to reduce the current consumption down to 1 μ A. To switch the sensor to power-down mode, the EN pin needs to be connected to the ground (low level).

A power on reset (POR) generator generates a reset signal when power is applied to the sensor in order to start operation in default configuration. This reset signal has an internal pull-up resistance. An external reset is also available through the RSTB pin. The reset signal is produced when the RSTB pin is connected to the ground (low level). In normal operation, the RSTB pin needs to be connected to VDD (high level).

4.3 Filtering

The reference voltage (GREF) used for excitation and actuation is filtered externally using a 100 μ F capacitor to achieve the required noise performance. This capacitor should have low Equivalent Series Resistance (ESR < 1 Ω) and low leakage currents (<6 μ A).

The control voltage of the clocking PLL (PLLLF) is filtered externally using a low-pass filter consisting of a 330nF capacitor in parallel to a series combination of 5.6 μ F capacitor and 5k Ω resistor. All of the PLL loop filter capacitors must have a leakage current less than 1 μ A.

4.4 SPI interface

The sensor has a four-wire SPI interface for communication and operates as a slave. In order to initiate the communication, the chip select CSB pin must be connected to the ground (low level). The change in the data lines DIN and DOUT must be synchronized to the falling edge of the SPI clock SCLK, while the master and slave sample their input on the rising edge of SPI clock SCLK. The SPI communication characteristics are detailed in section 10.

4.5 Self-test

The sensor contains a continuous, automatic, self-test functionality that is able to detect internal faults that may impact the reliability of the output data. It is used to detect proper operation of the sensor. Self-test is running in parallel with the main functions of the sensor.

This self-test function is raising a flag as long as the sensor is operating properly.

It tests if the drive loop is in normal mode, which means the drive loop control provides stable drive oscillations amplitude.

The ST pin provides 5V as long as the sensor is operating properly and 0V as long as the previous condition is not fulfilled. The ST pin can be connected to an interrupt input.

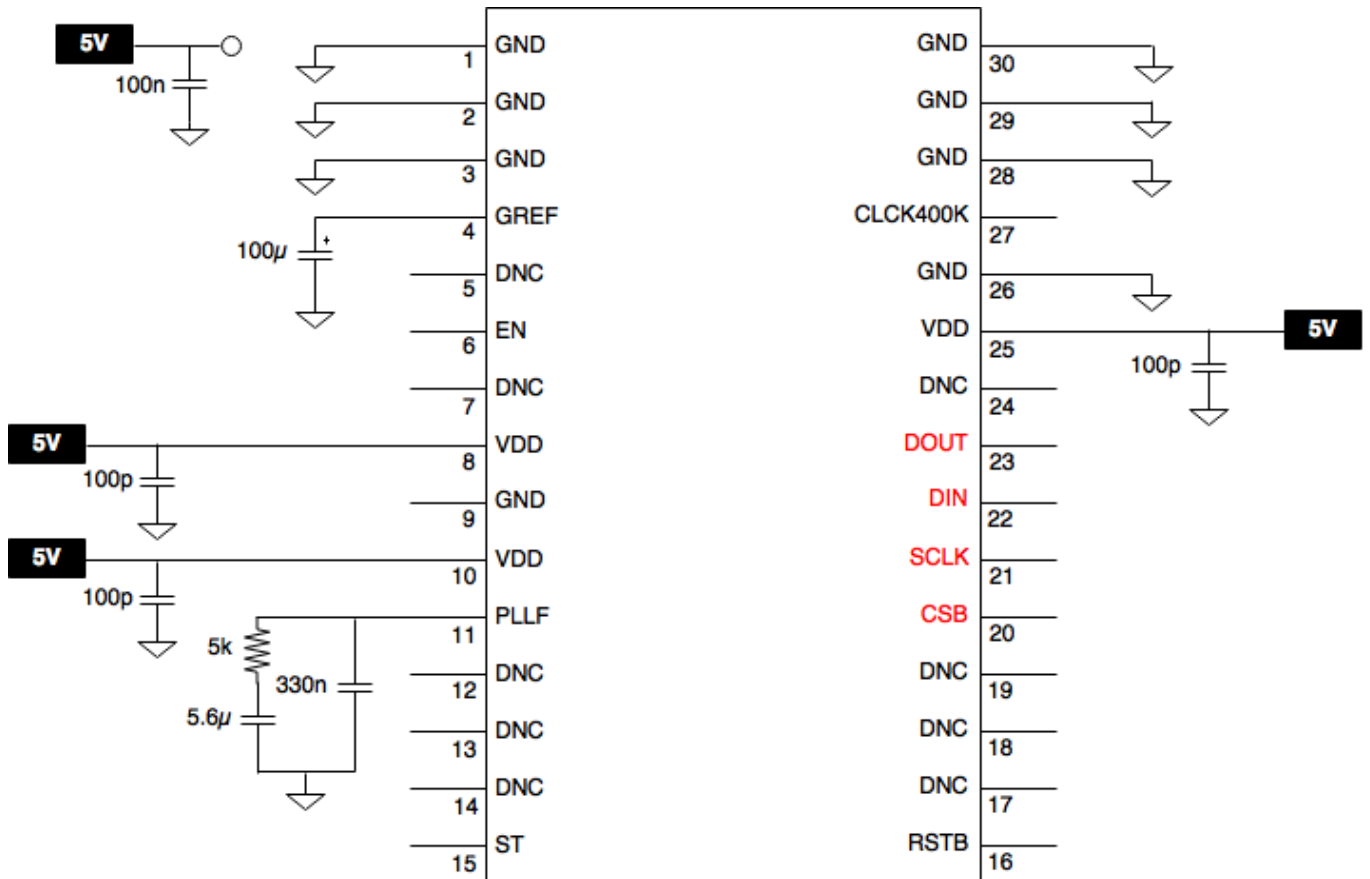

Figure 5: Application circuit for sensor operation

5 Soldering guidelines

5.1 Reflow profile

Tronics recommends following the standards defined in IPC/JEDEC J-STD-020D.1 (Reflow 5.6). Please note that the reflow profile to be used does not depend only on the sensor. The whole populated board characteristics have to be taken into account.

If a non-self-cleaning paste is used, a cleaning of the board has to be done in order to remove the residual flux which can cause short circuits between adjacent pads.

For a better reliability of the soldering, Tronics recommends using Copper-Invar-Copper or ceramic boards. These types of boards have a coefficient of thermal expansion (CTE) close to the CTE of GYPRO2300 package (6.8 ppm/°C).

The following profile comes from IPC/JEDEC J-STD-020D.1

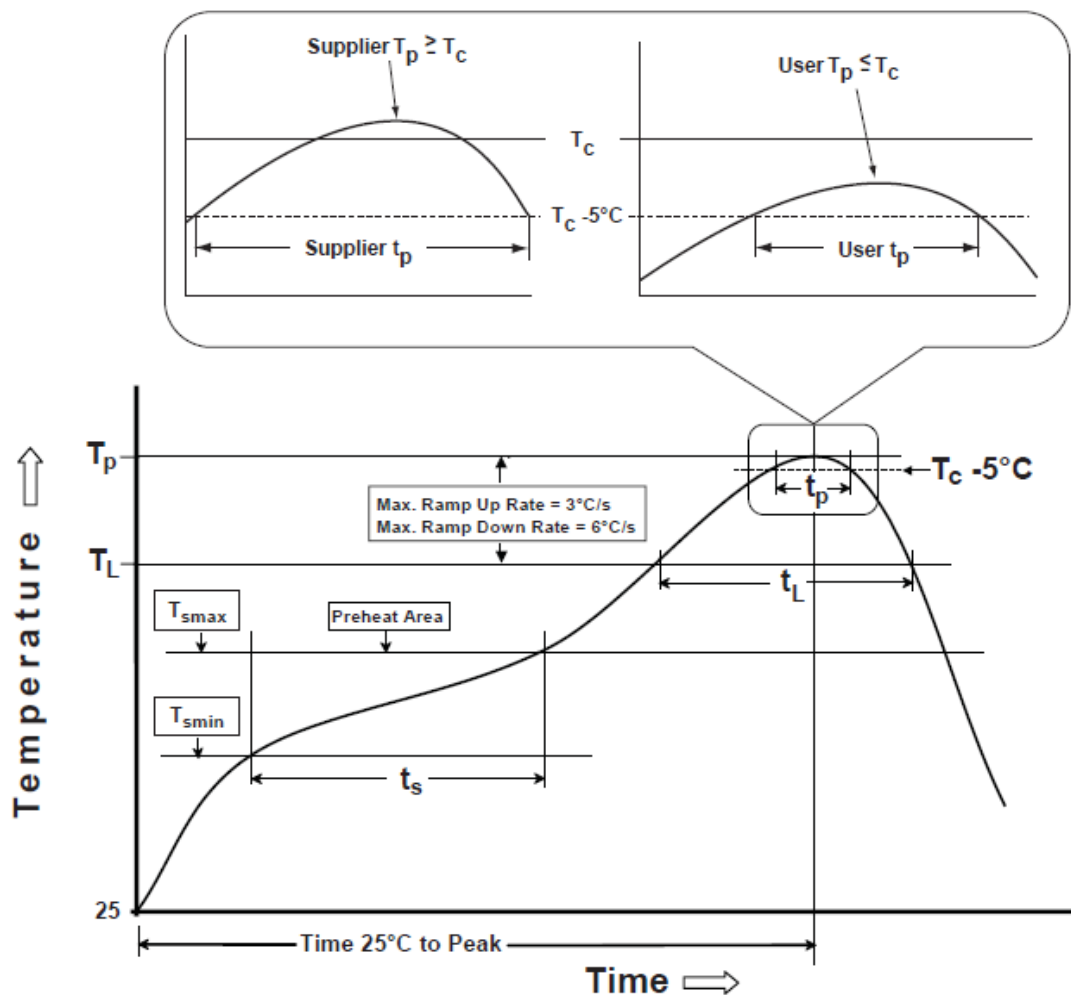

IPC-020d-5-1

Figure 6: Recommended reflow profile (JEDEC)

Profile Feature	Sn-Pb Eutectic Assembly	Pb-Free Assembly
Average Ramp-Up Rate (t_{smax} to t_p)	3°C/second max.	3°C/second max.
Preheat Temperature Min (T_{smin}) Temperature Max (T_{smax}) Time (t_s)	100°C 150°C 60-120 seconds	150°C 200°C 60-180 seconds
Time maintained above Temperature (T_L) Time (t_L)	183°C 60-150 seconds	217°C 60-150 seconds
Peak Temperature (T_p)	240°C (+/-5°C)	260°C (+/-5°C)
Time within 5°C of Actual Peak Temperature (t_p)	10-30 seconds	10-40 seconds
Ramp-Down Rate	6°C/second max.	6°/second max.
Time 25°C to Peak Temperature	6 minutes max.	8 minutes max.

Table 2 : Reflow profile characteristics (JEDEC)

5.2 PCB Footprint

PCB footprint dimensions are presented below:

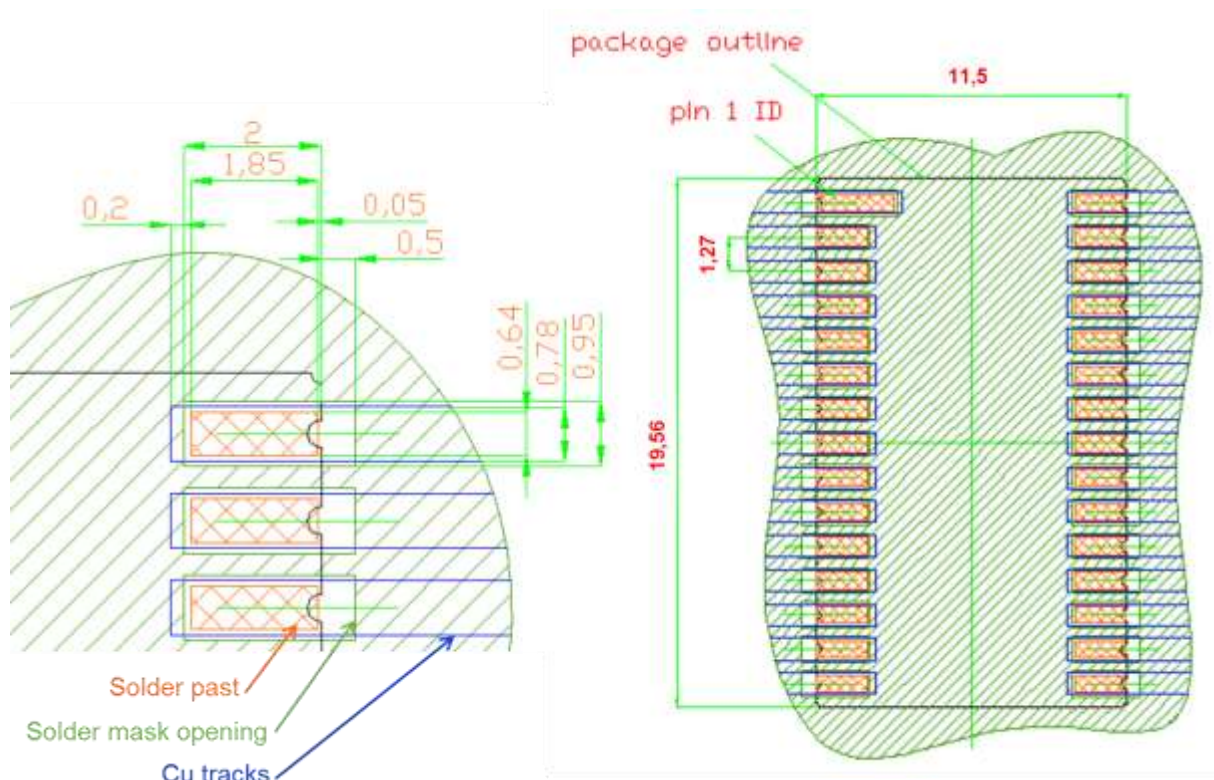

Figure 7: PCB Footprint

6 Specifications

6.1 Mechanical Characteristics

Unless specified in brackets, GYPRO2300LD characteristics are the same as GYPRO2300.

Parameter (*)		Test(**)	Typical	Max	Unit
1.	Input range	T	± 300	± 450	°/s
2.	Bandwidth	D	100 (200)		Hz
3.	Data rate	D	200 (1600)		Hz
4.	Latency	D	40 (2)		ms
5.	Nominal scale factor	T	10 ⁴		LSB/°/s
6.	Scale factor non-linearity	TRT	230	500	ppm
7a.	Scale factor variation over temperature (peak to peak)	T		0.5	%
7b.	Scale factor variation over temperature (1 σ)	Q	1000		ppm
7c.	Scale factor variation over temperature (1 σ , post-processed raw output)	Q	300		ppm
8.	Run to run scale factor repeatability	Q	450		ppm
9a.	Bias variation over temperature (peak to peak)	T		0.2	°/s
9b.	Bias variation over temperature (1 σ)	Q	140		°/h
9c.	Bias variation over temperature (1 σ , post-processed raw output)	Q	20		°/h
10.	Run to run bias repeatability	Q	10		°/h
11.	Bias instability	Q	0.8		°/h
12.	Short term bias stability	Q	30		°/h
13.	RMS Noise [1-100Hz]	TRT		0.05	°/s
14.	Angular random walk	Q	0.14		°/√h
15.	Start-up time	Q	0.8		s
16.	Recovery time	Q	10		ms
17.	G-sensitivity	Q	18		°/h/g
18.	Bias error under vibration	Q	10		°/h/g ² rms
19.	Rate axis misalignment	D		16	mrad
20.	Cross-axis sensitivity	Q	0.3		%

Table 3 : Mechanical characteristics

() Type of test:**

T: 100% tested in production.

TRT: 100% tested in production at room temperature.

Q: Measured during design qualification.

D: Results from design simulation.

(*) Definition of parameters:

1. Typical value is the range over which the performance are guaranteed. Maximum value corresponds to the limitation of the output.
2. The frequency region within the angular rate is measured with attenuation smaller than -3dB, expressed by stating the 3dB cut-off frequency. Please refer to Figure 13.
3. The refresh rate of the output data at room temperature. Please refer to section 11.1.
4. The group delay of the filtering chain given by design.
5. The ratio of a change in output to a change in the input intended to be measured. The scale factor is set during the sensor calibration.
6. The max deviation of the output from the expected value using a best fit straight line.
7.
 - a. The peak to peak deviation of the scale factor over operating temperature range, using the temperature compensated output of the gyro (built-in 2nd order polynomial fit).
 - b. The standard deviation of the scale factor over operating temperature range, using the temperature compensated output of the gyro (built-in 2nd order polynomial fit).
 - c. The standard deviation of the scale factor over operating temperature range, using the raw output and post-processing based on a 3rd order polynomial fit.
8. The standard deviation of seven scale factor measurements made at room temperature. The repeatability involves changes in measurements made under the same operating conditions that occur between seven periods of operation due to shut downs and 30 min power off between runs.
9.
 - a. The peak to peak deviation of the bias over operating temperature range, using the temperature compensated output of the gyro (built-in 2nd order polynomial fit).
 - b. The standard deviation of the bias over the operating temperature range, using the temperature compensated output of the gyro (built-in 2nd order polynomial fit).
 - c. The standard deviation of the bias over operating temperature range, using the raw output and post-processing based on a 3rd order polynomial fit.
10. The standard deviation of seven zero rate output measurements made at room temperature. The repeatability involves changes in measurements made under the same operating conditions that occur between seven periods of operation due to shut downs and 30 min power off between runs.
11. The bias instability coefficient by forming the Allan variance estimates from 4 hours zero rate output at room temperature.
12. The standard deviation of the filtered gyro output over 1 hour zero rate output at room temperature, after 30min for temperature stabilization. The sensor output is filtered using a moving average of 1 sec.

13. The RMS noise level at the output of the sensor in the band [1-100Hz]. This value has been obtained by integrating the power spectral density of the sensor output between 1 and 100Hz at zero rate.
14. The angular random walk coefficient obtained by forming the Allan variance estimates from 4 hours zero rate output at room temperature.
15. The time interval between the application of power and the presence of a usable output of the sensor (at least 90% of the input rate).
16. The time interval between the application of an impact (half sine 50 g, 6 ms) and the presence of a usable output of the sensor.
17. The component of systematic drift rate correlated with the first power of a linear acceleration component. The g-sensitivity is the mean value over all axis of the change in gyro output to 1 g.
18. The bias rectification under vibration along all axis, overall level 4 g rms (see Figure 8).
19. Misalignment between the rate axis and the perpendicular to the package bottom plane.
20. The output induced from the application of angular rate on a perpendicular axis.

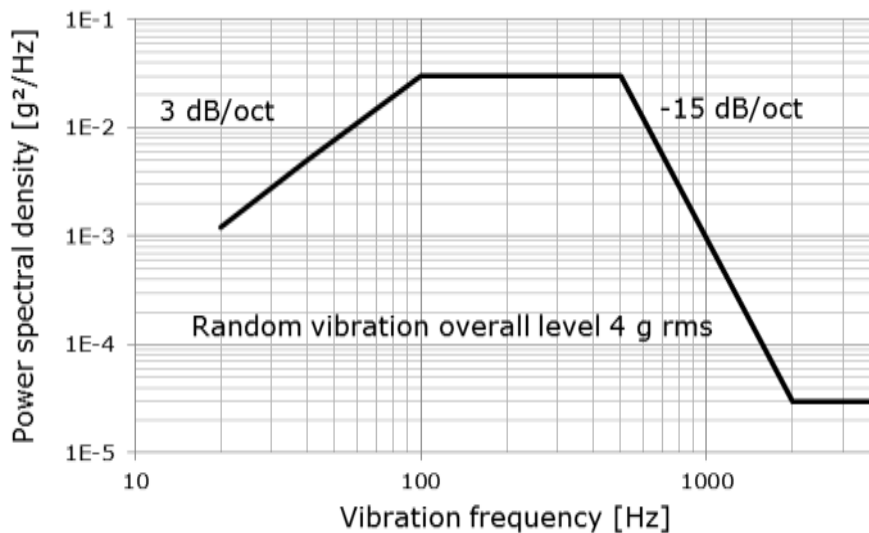

Figure 8: Random vibration profile for bias rectification

6.2 Electrical characteristics

Parameter	Test*	Min	Typical	Max	Units
Power Supply Voltage	D	4.75	5	5.25	V
Current consumption in normal mode	TRT		25		mA
Current consumption in power down mode	TRT		1	5	µA
Power supply rejection ratio	Q		20		°/hr/V

Table 4 : Electrical characteristics

(*) Type of test:

TRT: 100% tested in production at room temperature.

Q: Measured during design verification.

D: Results from design simulation.

6.3 Environmental conditions

The specifications apply within the following environment conditions:

Parameter	Test*	Min	Typical	Max	Units
Operating temperature range	T	-40		+85	°C
Humidity at 45°C	Q			98	%

Table 5 : Environmental conditions

(*) Type of test:

T: 100% tested in production.

Q: Measured during design verification.

6.4 Maximum ratings

Stresses above those listed under the maximum ratings below may cause permanent damage to the device. This is a stress rating only and functional operation of the sensor at these conditions or any other conditions above those indicated in the previous specifications is not implied.

Exposure to maximum ratings conditions for extended periods may affect device reliability.

Parameter	Min	Max	Units
Supply Voltage	-0.5	7	V
Electrostatic discharge Protection at any pin (ESD) Human body model		±2	kV
Storage temperature range	-55	+100	°C
Shock survival, acceleration applied on any axis during 0.3 ms		±2 000	g
Vibration survival, random acceleration applied on any axis within bandwidth 20Hz to 2kHz during 10 min		±20	grms
Exposure to ultra sonic cleaning		Not allowed	

Table 6 : Maximum ratings

6.5 ESD caution



The product may be damaged by ESD, which can cause performance degradation or device failure. We recommend handling the device only on a static safe work station. Precautions for the storage should also be taken.

It is forbidden to keep SPI pads at a high level while VDD is at 0V due to ESD protection diodes and buffers. The sensor must be powered-on before any SPI operation, like connecting or disconnecting. Any other procedure may damage the sensor.

7 Typical performance characteristics

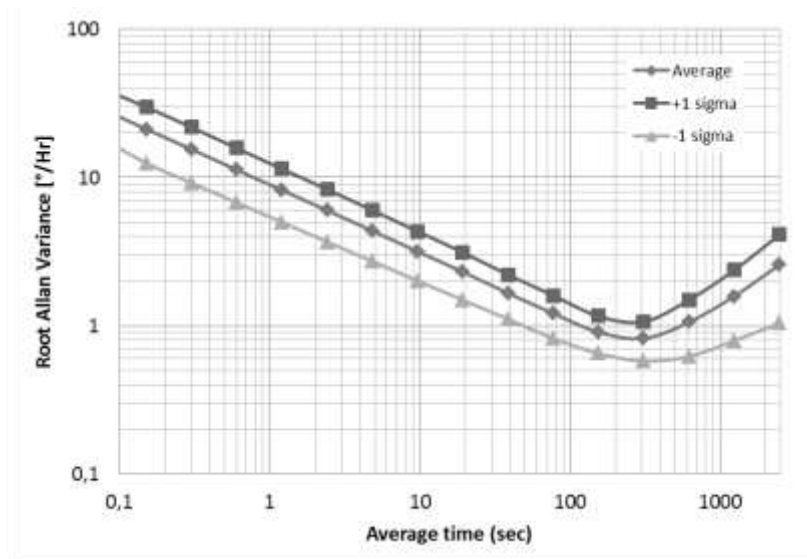

Figure 9: Root Allan variance at room temperature

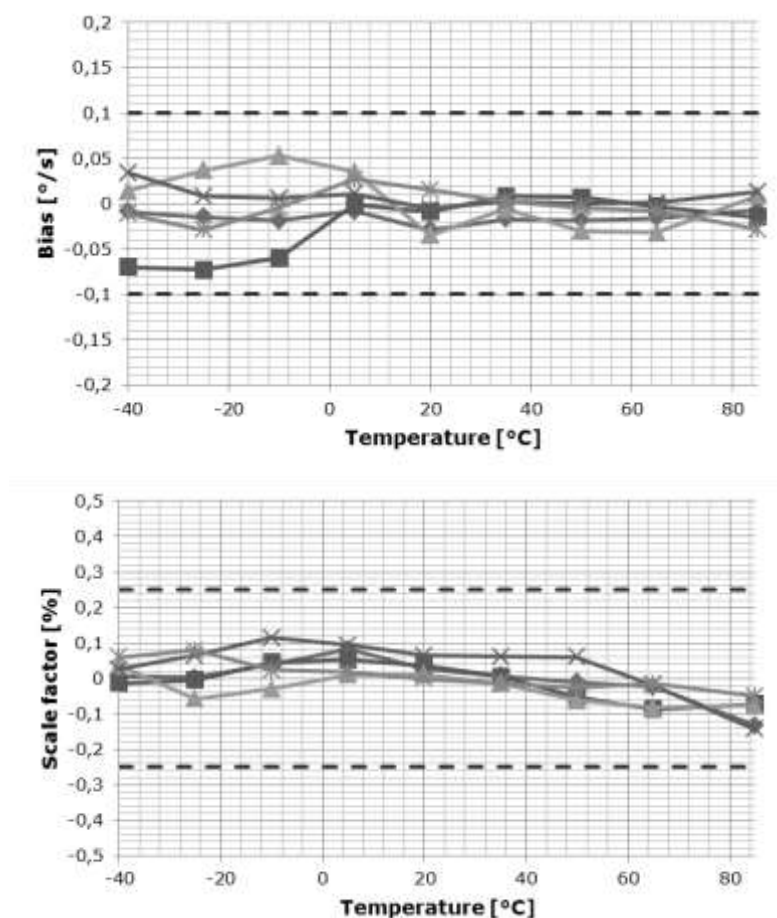

Figure 10: Temperature-compensated Bias and Scale Factor versus temperature
Dotted lines correspond to the max specifications

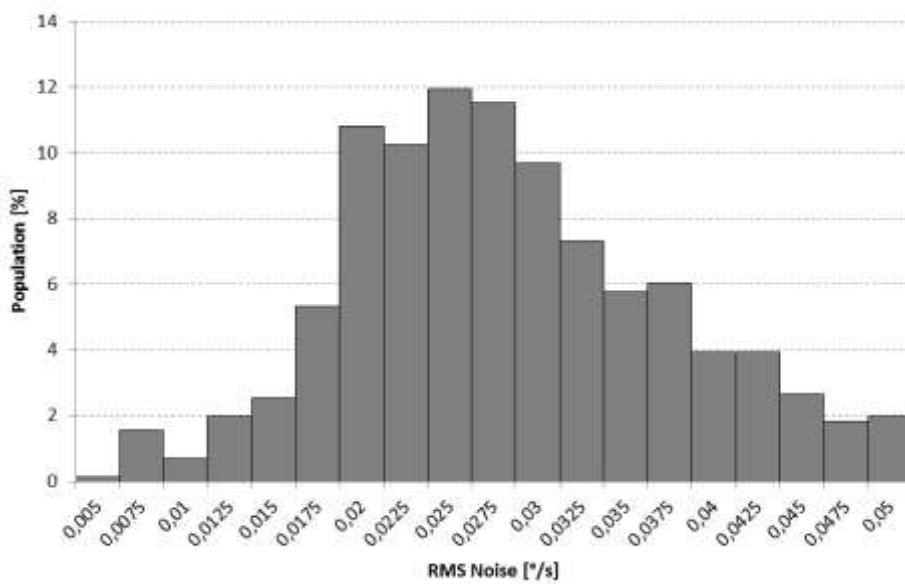

Figure 11: GYPRO2300 RMS noise distribution on 500 sensors

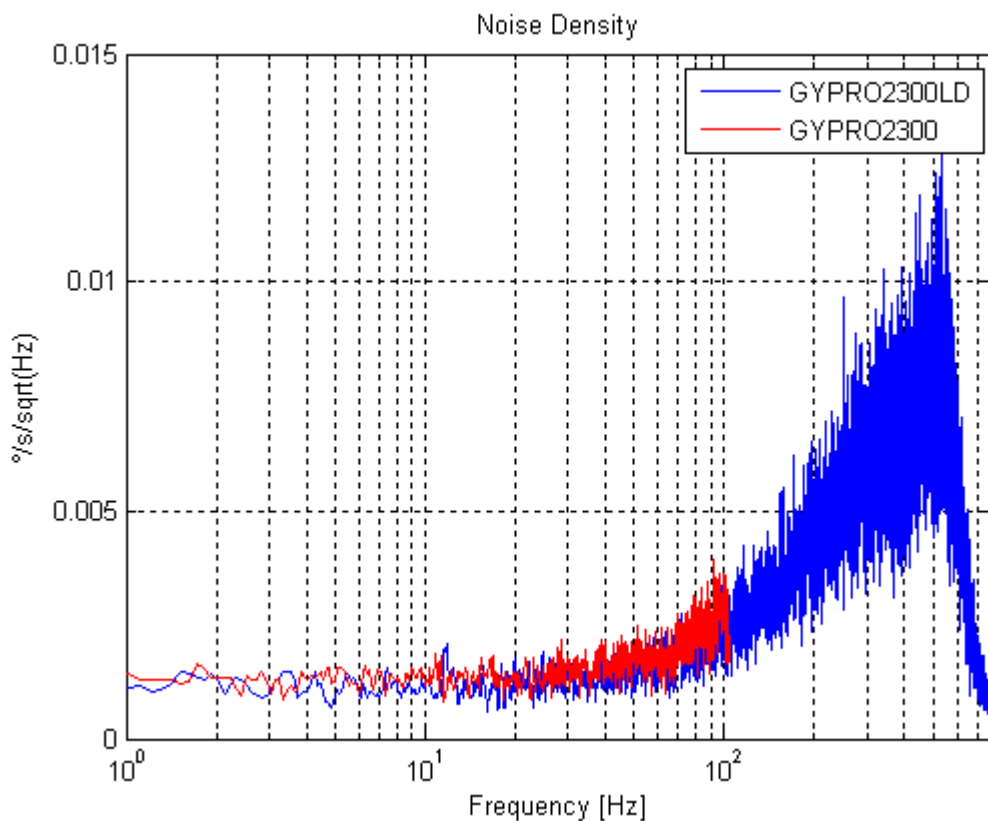

Figure 12: Noise density for GYPRO2300 and GYPRO2300LD (typical)

Gypro2300LD allows a 'low-delay' configuration where the latency can be decreased from 40 ms down to 2ms by bypassing some components of the filtering chain. Consequently, in this low-delay configuration, the data rate of the GYPRO2300LD is increased to 1600Hz and the bandwidth is 200Hz (versus data rate of 200Hz and bandwidth of 100Hz for GYPRO2300). **However, the customer should filter the signal to [DC-100Hz] so that noise characteristics remain unchanged**, as it is shown on Figure 12.

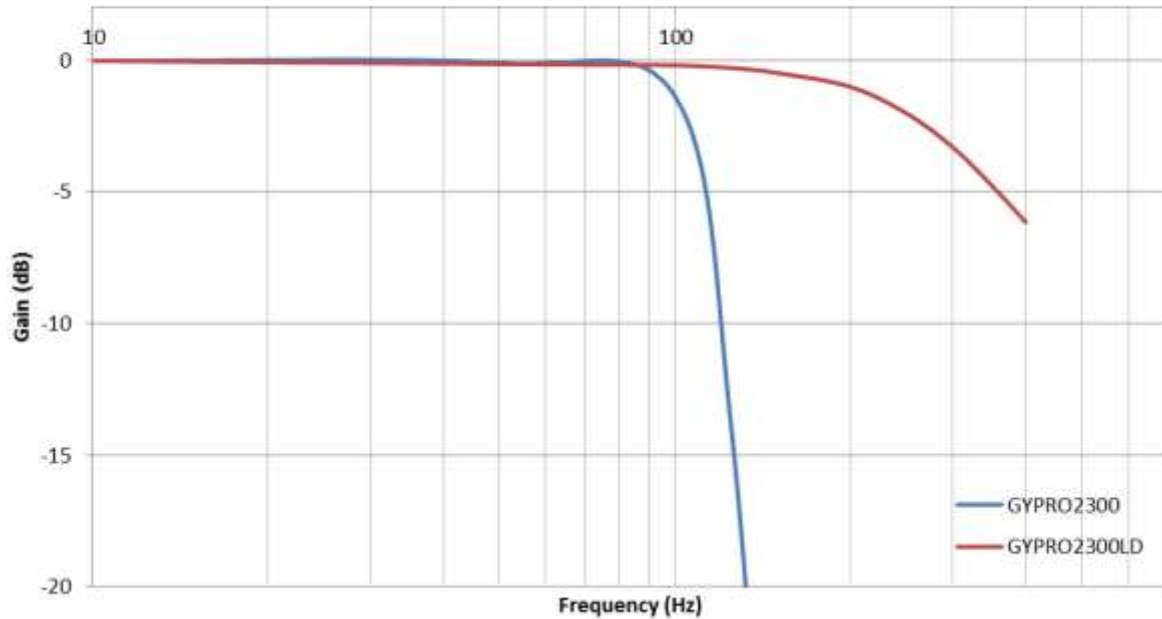

Figure 13: GYPRO2300 and GYPRO2300LD frequency response

8

8 Temperature-compensation procedure for the angular rate output

8.1 Purpose

During factory calibration, each sensor is already compensated for temperature effects over the operating temperature range. Nevertheless, this compensation has been obtained for a specific assembly configuration. Different assembly configurations can lead to minor errors in the bias and scale factor over the operating temperature range due to a non-optimized compensation.

So, for better performances over temperature, it is recommended to optimize the compensation for the targeted assembly configuration. The section 8.3 describes the procedure to get the compensation parameters. The section 11.4.7 describes how to store the obtained parameters into the non-volatile memory.

8.2 Algorithm overview

After filtering, the raw angular rate sensor output is temperature-compensated based on the on-chip temperature sensor output and the stored temperature compensation parameters.

The temperature compensated angular rate sensor output can be modeled as follows:

$$\text{COMP_ROUT} = \text{dsf} \cdot \text{rin} = \text{dsf} \cdot (\text{RAW_ROUT} - \text{b}) / \text{sf} \dots\dots\dots \text{(a)}$$

where,

Term	Definition	Unit
COMP_ROUT	temperature compensated angular rate sensor output	[LSB]
rin	input rate	[°/s]
dsf	desired scale factor	[LSB/°/s]
RAW_ROUT	raw angular rate sensor output	[LSB]
b	bias of the raw angular rate sensor output	[LSB]
sf	scale factor of the raw angular rate sensor output	[LSB/°/s]

The temperature compensated angular rate sensor output is proportional to the input rate and the desired scale factor is set to 10 000 LSB/°/s providing an output with a resolution of 0.0001°/s.

The bias and the scale factor of the raw angular rate sensor output with respect to temperature can be modeled as follows:

$$\begin{aligned} \text{b} &= \text{b0} + \text{b1} \cdot (\text{RAW_TOUT} - \text{TMID}) + \text{b2} \cdot (\text{RAW_TOUT} - \text{TMID})^2 \\ \text{sf} &= \text{sf0} + \text{sf1} \cdot (\text{RAW_TOUT} - \text{TMID}) + \text{sf2} \cdot (\text{RAW_TOUT} - \text{TMID})^2 \dots\dots\dots \text{(b)} \end{aligned}$$

where,

Term	Definition
RAW_TOUT	raw temperature sensor output
TMID	raw temperature sensor output at mid-temperature point
b0	zero-order coefficient for bias compensation
b1	first-order coefficient for bias compensation
b2	second-order coefficient for bias compensation
sf0	zero-order coefficient for scale factor compensation
sf1	first-order coefficient for scale factor compensation
sf2	second-order coefficient for scale factor compensation

8.3 Procedure

In order to compute the six coefficients b_0 , b_1 , b_2 , sf_0 , sf_1 and sf_2 , three temperature points are needed.

The stored temperature compensation coefficients have been obtained using the following temperature points:

Term	Definition	Temperature point
TMID	raw temperature sensor output at mid-temperature point	+ 20°C
TLOW	raw temperature sensor output at low temperature point	- 40°C
THIGH	raw temperature sensor output at high temperature point	+ 85°C

These temperature points are recommended to minimize the bias and scale factor error from -40°C to +85°C (Different temperature points can be used to optimize the compensation over a different temperature range).

At each temperature point, the bias and scale factor need to be evaluated. The bias is obtained from the measurement of the raw angular rate sensor output for zero input rate. The scale factor is obtained from the measurement of the raw angular rate sensor outputs for $\pm 300^\circ/s$ input rates. Please note that it is important to wait for thermal stabilization before recording the different readings for each temperature point.

Term	Definition	Unit
B_TMID	measured bias at mid-temperature point	[LSB]
B_TLOW	measured bias at low temperature point	[LSB]
B_THIGH	measured bias at high temperature point	[LSB]
SF_TMID	measured scale factor at mid-temperature point	[LSB/°/s]
SF_TLOW	measured scale factor at low temperature point	[LSB/°/s]
SF_THIGH	measured scale factor at high temperature point	[LSB/°/s]

From the measured temperatures, biases and scale factors, one can compute the coefficients as follows:

$$b_2 = ((B_TLOW - B_TMID) / (TLOW - TMID) - (B_THIGH - B_TMID) / (THIGH - TMID)) / (TLOW - THIGH)$$

$$b_1 = (B_TLOW - B_TMID) / (TLOW - TMID) - b_2 \cdot (TLOW - TMID)$$

$$b_0 = B_TMID$$

$$sf_2 = ((SF_TLOW - SF_TMID) / (TLOW - TMID) - (SF_THIGH - SF_TMID) / (THIGH - TMID)) / (TLOW - THIGH)$$

$$sf_1 = (SF_TLOW - SF_TMID) / (TLOW - TMID) - sf_2 \cdot (TLOW - TMID)$$

$$sf_0 = SF_TMID \dots\dots\dots(c)$$

The raw temperature sensor output and angular rate sensor output words are respectively an unsigned 20 bits word and a signed 24 bits word (two's complement notation) in the equation (c). So the temperature reading from the SPI registers must be multiplied by 256 and the angular rate sensor reading unchanged (see section 11.3). The obtained coefficients are scaled and converted into hexadecimal values (two's complement notation) to be written in the corresponding registers according to the procedure described section 11.4.4.

Register	Default values (hex)	Calculated values (dec)	Width (bits)	Format
B2	0	$b2 \cdot 2^{28}$	16	signed 2's comp
B1	0	$b1 \cdot 2^{20}$	30	signed 2's comp
B0	0	b0	30	signed 2's comp
SF2	0	$sf2 \cdot 2^{55} / dsf$	16	signed 2's comp
SF1	0	$sf1 \cdot 2^{46} / dsf$	30	signed 2's comp
SF0	0x08000000	$sf0 \cdot 2^{27} / dsf$	30	signed 2's comp
TMID	0	TMID	20	unsigned

8.4 Typical Walkthrough

- Select the raw angular rate output as the angular rate output of the SPI register switching the register GOUT_SEL from 0 to 1 (refer to 11.4.1 for the register definition)
 - Send RSYST_02* to read the 32-bits word including the system register GOUT_SEL,
 - Modify only the bit 27 corresponding to the system register GOUT_SEL,
 - Send WSYST_02* to write the modified 32 bits word including the new system register GOUT_SEL.
- Select the raw temperature output as the temperature output of the SPI register switching the register TOUT_SEL from 1 to 0 (refer to 11.4.2 for the register definition)
 - Send RSYST_09* to read the 32-bits word including the system register TOUT_SEL,
 - Modify only the bit 2 corresponding to the system register TOUT_SEL,
 - Send WSYST_09* to write the modified 32 bits word including the new system register TOUT_SEL.
- Set the climatic chamber temperature to low temperature,
 - Wait for thermal stabilization,
 - Send RDTO** to get TLOW,
 - Set the table rate to 0°/s,
 - Send RDGO*** to get B_TLOW,
 - Set the table rate to +300°/s,
 - Send RDGO*** to get RAW_ROUT for +300°/s,
 - Set the table rate to -300°/s,
 - Send RDGO*** to get RAW_ROUT for -300°/s,
 - Compute SF_TLOW from previous measurements
- Repeat the same steps for mid and high temperatures.
- Compute b0, b1, b2, sf0, sf1 and sf2 using equation (c).
- Send WRSF2B2 to write the 32 bits word including the new system registers SF2 and B2.
- Send WRB1 to write the 32 bits word including the new system register B1.
- Send WRB0 to write the 32 bits word including the new system register B0.
- Send WRSF1 to write the 32 bits word including the new system register SF1.
- Send WRSF0 to write the 32 bits word including the new system register SF0.
- Send WRTMID to write the 32 bits word including the new system register TMID.
- Update the available MTP slots status (see section 11.3.5).

*** SPI frame mnemonic as described section 11.3.1

** SPI frame mnemonic as described section 11.3.2

* SPI frame mnemonic as described section 11.4

9 Calibration procedure for the temperature sensor

9.1 Purpose

The on-chip temperature sensor **is not factory-calibrated**. Please note that the on-chip temperature sensor calibration is not required to compensate the angular rate sensor output with respect to the temperature as described in section 8.3. However, the temperature sensor can be calibrated to output an absolute temperature reading from the on-chip temperature sensor.

9.2 Algorithm overview

The temperature sensor output can be modeled as follows:

$$\text{CAL_TOUT} = \text{dg} \cdot \text{TK} = \text{g} \cdot \text{RAW_TOUT} + \text{o} \quad \dots\dots\dots \text{(a)}$$

where,

Term	Definition	Unit
CAL_TOUT	calibrated temperature sensor output	[LSB]
TK	absolute temperature	[°K]
dg	desired gain	[LSB/°K]
RAW_TOUT	raw temperature sensor output	[LSB]
o	offset	[]
g	gain	[]

The raw temperature sensor output is proportional to the absolute temperature and the desired gain is set to 20 LSB/°K providing an output with a resolution of 0.1°K.

9.3 Procedure

In order to compute the coefficients o and g, 2 temperature points are needed.

Term	Definition	Unit
TLOW	raw temperature sensor output at low temperature point	[LSB]
TKLOW	absolute temperature at low temperature point	[°K]
THIGH	raw temperature sensor output at high temperature point	[LSB]
TKHIGH	absolute temperature at high temperature point	[°K]

From the measured temperatures (12 bits word), one can compute the coefficients as follows:

$$\text{g} = \text{dg} \cdot (\text{TKLOW} - \text{TKHIGH}) / (\text{TLOW} - \text{THIGH})$$

$$\text{o} = \text{dg} \cdot \text{TKLOW} - \text{g} \cdot \text{TLOW} \quad \dots\dots\dots \text{(b)}$$

Finally, the obtained coefficients are scaled and converted into hexadecimal values to be written in the corresponding registers according to the procedure described section 11.4.3. The register TOUT_SEL is used to select the calibrated temperature sensor output as the temperature output reading of the SPI register.

System Register	Default value (hex)	New value (dec)	Width (bits)	Address	Bits
G	0x0800	$g \cdot 2^{09}$	12	4	[13:2]
O	0	o	12	4	[27:16]
TOUT_SEL	0	1	1	9	[2:2]

9.4 Typical Walkthrough

- Set the climatic chamber temperature to low temperature,
- Wait for thermal stabilization,
- Send RDTO** to get TLOW,
- Measure the climatic chamber temperature TKLOW,

- Set the climatic chamber temperature to high temperature,
- Wait for thermal stabilization,
- Send RDTO** to get THIGH,
- Measure the climatic chamber temperature TKHIGH,

- Compute g and o using equation (b),

- Send RSYST_04* to read the 32-bits word including the system registers G and O,
- Modify only the bits [13:2] and [27:16] corresponding respectively to the system registers G and O,
- Send WSYST_04* to write the modified 32 bits word including the new system registers G and O,

- Send RSYST_09* to read the 32-bits word including the system register TOUT_SEL,
- Modify only the bit 2 corresponding to the system register TOUT_SEL=1,
- Send WSYST_09* to write the modified 32 bits word including the new system register TOUT_SEL.

*** SPI frame mnemonic as described section 11.3.1

** SPI frame mnemonic as described section 11.3.2

* SPI frame mnemonic as described section 11.4

10 Digital Interface

The GYPRO2300 sensor provides a SPI 4-wire slave digital interface. The digital interface is used to make the regular reading of data registers. Only the SPI mode 0 is supported (clock polarity CPOL=0, clock phase CPHA=0).

The following sections detail the SPI interface and communication characteristics.

10.1 Electrical characteristics

Symbol	Parameter	Condition	Min	Typical	Max	Units
VIL	Low level input voltage		0		0.1 x VDD**	V
VIH	High level input voltage		0.8 x VDD**		VDD**	V
VOL	Low level output voltage	ioL=0mA (Capacitive Load)		GND		V
VOH	High level output voltage	ioH=0mA (Capacitive Load)		VDD**		V
Rpull_up	Pull-up resistor*	Internal pull-up resistance to VDD		100		kΩ
Rpull_down	Pull-down resistor	Internal pull-down resistance to GND		-		kΩ

* Only used for Reset input

** Power Supply VDD = 5V typical

Table 7 : Digital interface electric characteristics

In order to initiate the communication, the CSB level must be kept low. The change in the data lines DOUT and DIN must be synchronized to the falling edge of the SCLK, while the master and slave sample their inputs on the rising edge of SCLK.

The DOUT pin is kept in high impedance when the CSB level is high, which allows sharing the SPI bus with other components.

Different scenarios for SPI communication are shown in the following figure.

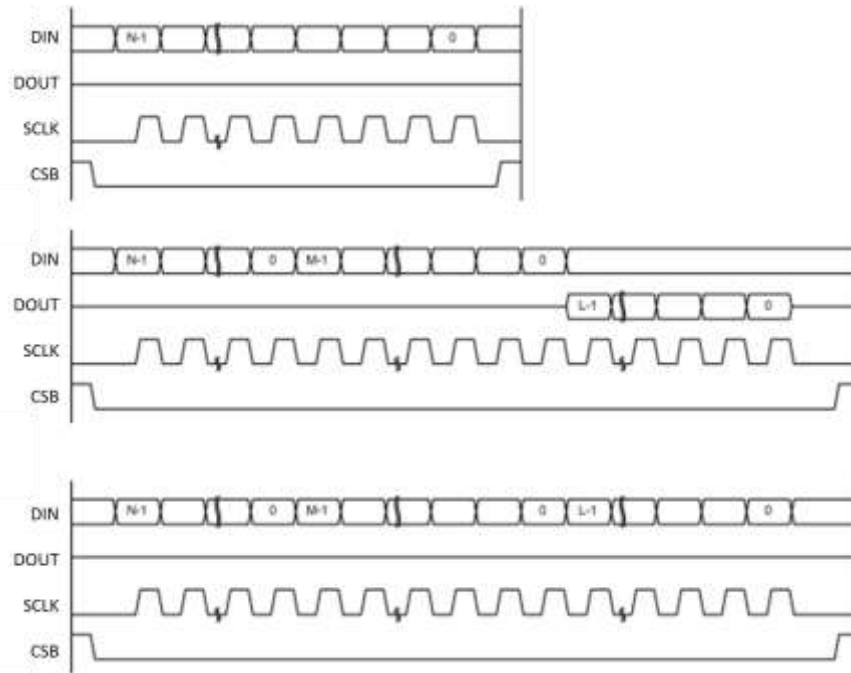

Figure 14: Different scenarios for SPI communication

10.2 Timing parameters

Symbol	Parameter	Condition	Min	Typical	Max	Units
Fspi	SPI clock input frequency	Maximal load 25pF on DIN or DOUT		0.2	8	MHz
T_low_sclk	SCLK low pulse		62.5			ns
T_high-sclk	SCLK high pulse		62.5			ns
T_setup_din	DIN setup time		10			ns
T_hold_din	DIN hold time		5			ns
T_delay_dout	DOUT output delay	Load 25pF			40	ns
T_setup_csb	CSB setup time		1			Tsclk
T_hold_csb	CSB hold time		1			Tsclk

Table 8 : SPI timing characteristics

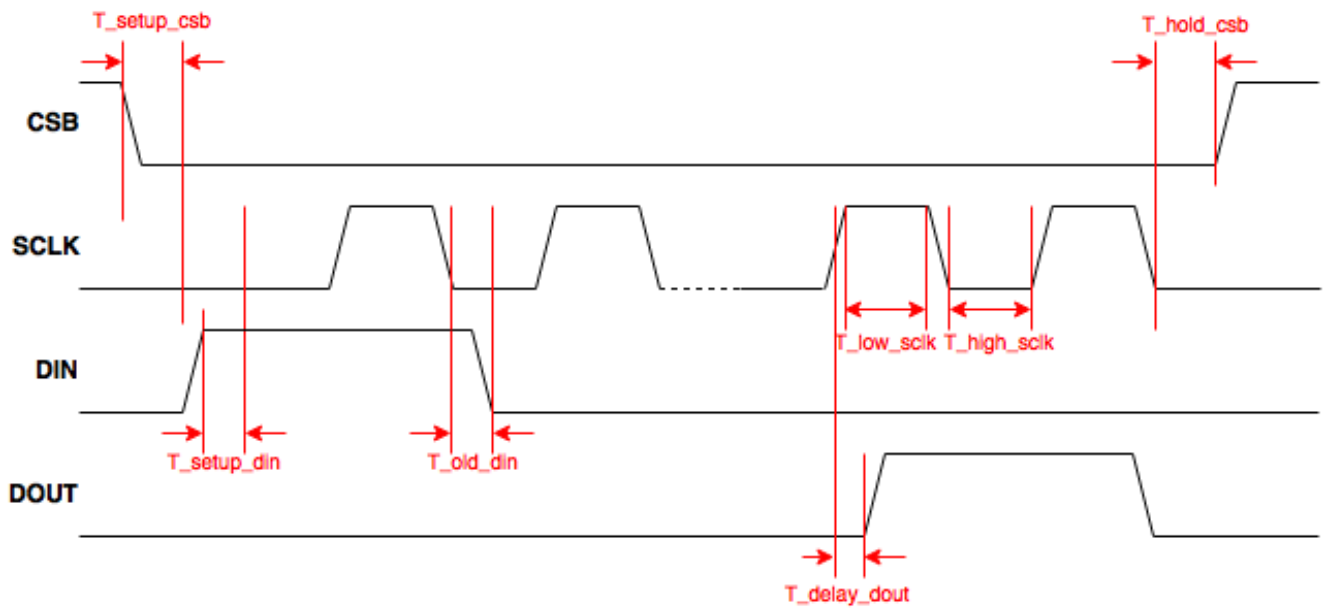

Figure 15 : SPI timing diagram

10.3 SPI recommendations

It is forbidden to keep SPI pads at a high level while VDD is at 0V due to ESD protection diodes and buffers.

SPI pad voltages must be kept between GND - 0.3V and VDD + 0.3V.

11 Registers and SPI frames

The device functionality is controlled through its interface registers. The device registers are divided into two register parts, the SPI Register and the System Register. The device system controller manages the interface between the registers thanks to the SPI protocol.

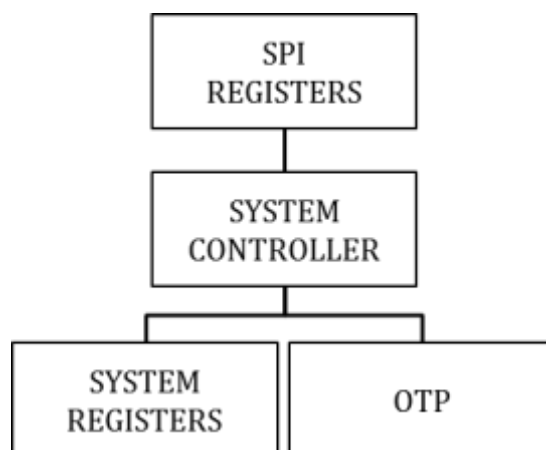

Figure 16 : Interface between the registers and the system controller

The SPI Register provides a simple interface to read and calibrate the angular rate output and the temperature output, while the System Registers hold the trimming (TRONICS reserved) and the programmable features data of the different IC blocks.

The SPI Register can be directly accessed through the device SPI Interface while the System Register is accessed indirectly through the SPI register by writing the appropriate SPI command.

Trimming and temperature compensation coefficients are stored within the chip in a non-volatile memory. Only the temperature compensation coefficients are re-programmable via MTP (Multi-Time-Programmable). There are 8 user-programmable instances of 32x32 bits.

The following subsections describe the clock system, SPI Register, System Register and the detailed processes to read and write those registers.

11.1 Clock System

There are two independent clocks in the sensor:

- SPI clock: this first clock is used for the communication through the SPI interface and is defined by the user.
- Internal clock: this second clock is defined by (and proportional to) the mechanical drive oscillation of the MEMS which varies slightly from component to component, due to the manufacturing process. This clock is used for all internal signals. Data rate is proportional to this internal clock.

11.2 SPI Register

The SPI register map consists of 14 slots, with addresses ranging from address 0x0 to 0xD. The SPI register address is a 4-bits word. Each SPI register is an 8-bit width data (from bit 0 to 7).

Registers from the address 0x0 to 0x3 are read only. As shown in the table below they contain gyro (angular rate) data and temperature data. Registers from the address 0x8 to 0xD allow accessing to the System Register thanks to a command (read/write), an address (register to read/write) and a data (to read/write).

SPI register map									
Address	Bit7	Bit6	Bit5	Bit4	Bit3	Bit2	Bit1	Bit0	
0x0	DATARDY								
0x1	Gyro_output [23:0]								
0x2									
0x3									TRONICS RESERVED
0x4	0	0	Temperature_output[11:0]						
0x5	TRONICS RESERVED								
0x6									
0x7									
0x8	System Register data [31:0]								
0x9									
0xA									
0xB									
0xC	System Register address [7:0]								
0xD	System Register command [7:0]								

Table 9 : SPI Register map

Name	Description	Width	R/W
DATARDY	This bit is used to indicate that a new gyro reading data is available. '1': The data has never been read and is available for reading '0': The data has already been read, it must be discarded	1	R
Gyro_output	Temperature compensated angular rate output	24	R
Temperature_output	Raw temperature sensor output	12	R
SIfTest	Self-test bit	1	R
System Register data	Data to read/write in the System Register	32	R/W
System Register address	System register address to read/write	8	R/W
System Register command	System register command (read or write)	8	R/W

Table 10 : Register slots description

The SPI frames used for the communication through the SPI Register are composed of a command and an address, followed by arguments.

The SPI command and address are 4-bit words each and the data (arguments) are composed of n X 8-bit words.

Command (4-bits)	Address (4-bits)	Arguments (n X 8-bits)	Description
0x5	SPI register address	n X 0x00	Read n X 8-bit data from the SPI address
0x7	SPI register address	Data	Write a n X 8-bits data to the SPI address

Table 11 : Basic SPI commands

Regarding the reading command, the address must be followed by one or several 0x00 data corresponding to the number of 8-bit slots to be read. The reading address is automatically incremented at each new 0x00 data sent.

Regarding the writing command, the address must be followed by one or several 8-bits data corresponding to the number of 8-bit slots to be written. The writing address is automatically incremented at each new 8-bit data sent.

11.3 Output Data

11.3.1 Reading the angular rate output

The gyro output (24-bit word) needs to be extracted from the 4 read registers (32-bit word). The gyro output is directly accessed via the SPI Register.

The SPI frame used to read the gyro output registers is presented below. The argument is 4 "0x00" data which mean that 4 registers are read from the address 0x0 (i.e. 0x0, 0x1, 0x2, 0x3).

Mnemonic	Command	SPI Register Address	Argument			
RDGO	0x5	0x0	0x00	0x00	0x00	0x00

Table 12 : Breakdown of the gyro output reading SPI frame

The following table presents the 4 read register slots including the 24-bit gyro output resulting from RDGO:

Address	Bit7 (msb)	Bit6	Bit5	Bit4	Bit3	Bit2	Bit1	Bit0 (lsb)
0x0	DATARDY	Gyro_Out[23]	Gyro_Out[22]	Gyro_Out[21]	Gyro_Out[20]	Gyro_Out[19]	Gyro_Out[18]	Gyro_Out[17]
0x1	Gyro_Out[16]	Gyro_Out[15]	Gyro_Out[14]	Gyro_Out[13]	Gyro_Out[12]	Gyro_Out[11]	Gyro_Out[10]	Gyro_Out[9]
0x2	Gyro_Out[8]	Gyro_Out[7]	Gyro_Out[6]	Gyro_Out[5]	Gyro_Out[4]	Gyro_Out[3]	Gyro_Out[2]	Gyro_Out[1]
0x3	Gyro_Out[0]	Tronics reserved						SelfTest

Table 13 : Gyro output data description

The 24-bit gyro output is coded in two's complement. To translate this value into an angular rate (°/sec), the 24-bit value has to be divided by the factor **10 000**.

-300.0000 °/s			⇔	1101 0010 0011 1001 0100 0000
...				
-0.0002 °/s	i.e. -0.72 °/h		⇔	1111 1111 1111 1111 1111 1110
-0.0001 °/s	i.e. -0.36 °/h		⇔	1111 1111 1111 1111 1111 1111
0.0000 °/s	i.e. 0.00 °/h		⇔	0000 0000 0000 0000 0000 0000
+0.0001 °/s	i.e. +0.36 °/h		⇔	0000 0000 0000 0000 0000 0001
+0.0002 °/s	i.e. +0.72 °/h		⇔	0000 0000 0000 0000 0000 0010
...				
+300.0000 °/s			⇔	0010 1101 1100 0110 1100 0000

11.3.2 Reading the temperature output

The temperature output (12-bit word) needs to be extracted from the 2 read registers (16-bit word). The temperature output is directly accessed via the SPI Register.

The SPI frame used to read the temperature output registers is presented below. The argument is 2 "0x00" data which mean that 2 registers are read from the address 0x4 (i.e. 0x4, 0x5).

Mnemonic	Command	SPI Register Address	Argument	
RDTO	0x5	0x4	0x00	0x00

Table 14 : Breakdown of the temperature output reading SPI frame

The following table presents the 2 read register slots including the 12-bit temperature output resulting from RDTO:

Address	Bit7 (msb)	Bit6	Bit5	Bit4	Bit3	Bit2	Bit1	Bit0 (lsb)
0x4	0	0	Temp_Out[11]	Temp_Out[10]	Temp_Out[9]	Temp_Out[8]	Temp_Out[7]	Temp_Out[6]
0x5	Temp_Out[5]	Temp_Out[4]	Temp_Out[3]	Temp_Out[2]	Temp_Out[1]	Temp_Out[0]	Tronics reserved	

Table 15 : Temperature output data description

11.4 Device Configuration

Different configurations of the sensor are selectable by writing bits in the System Register. This section explains the way to configure the sensor and to program the OTP accordingly using SPI frames.

For the purpose of communication to the System Register and the OTP, one can use the dedicated SPI Registers slots (from address 0x8 to 0xD).

The System Register map consists of 32-bit width registers (from bit 0 to 31). The System Register address is 8-bit coded.

System register map							
Address	B31	B30	B29	...	B2	B1	B0
0x0							
0x1							
0x2							
0x3							
0x4							
0x5							
0x6							
.							
.							
.							

Table 16 : System Register map

The following table describes the 8-bit commands used to access the System Register via the address 0xD of the SPI register.

Command	Description
0x01	Read from System Register
0x02	Write to System Register
0x04	Program all OTP
0x05	Copy all OTP to System Register
0x06	Program a certain address in the OTP
0x07	Copy a certain address
0x08	Read a certain address from OTP

Table 17 : System Register commands

The System Register reading command RSYST_m is described below. It is composed of two steps. The first one reads and copies the 32-bit data from the *Address_m* of the System Register to the addresses 0x8, 0x9, 0xA and 0xB slots of the SPI Register. The second step reads the addresses 0x8, 0x9, 0xA and 0xB of the SPI Register. Between the two steps, the CS pin has to be high during at least 10 SCLK periods.

Mnemonic	Command	SPI Register Address	Argument			Description
			Data	System Register Address	System Register Command	
RSYST_m	0x7	0xC	-	0xAddress_m	0x01	Read and copy the 32-bit data from the System Register to the SPI Register
	0x5	0x8	0x00000000	-	-	Read the copied data in the SPI Register
WSYST_m	0x7	0x8	32-bit data to write	0xAddress_m	0x02	Write the desired 32-bit data in the System Register

Table 18 : System Register general commands

Important Note: The System Registers contain critical IC and MEMS data. Unless otherwise specified, the data should not to be modified by the user. A reset procedure using the RSTB pin will reload the default memory values.

11.4.1 Raw/Temperature Compensated gyro output

The format of the angular rate output can be chosen to be either raw data or temperature-compensated data. The following table presents the dedicated register for the gyro output selection.

Name	Description	Width	Default	Address	Bit	R/W
GOUT_SEL	'0': T-compensated gyro data on the output '1': gyro raw data on the output	1	0	2	27	R/W

Due to the System Register structure, changing the gyro data format requires several steps. The other bits of the Address 0x02 should not be modified by the user. The gyro output selection procedure is described in the following table:

Step	Command	Description
1	RSYST_02	Read the initial 32-bits data of System Register at 0x02
2	-	Modify only the bit 27 of the 32-bits data
3	WSYST_02	Write the modified 32-bits data in the System Register at 0x02

Table 19 : Gyro data format selection procedure

11.4.2 Raw/Calibrated temperature output

The format of the temperature output can be chosen to be either raw data or calibrated data (please remind that temperature output is not factory-calibrated). The following table presents the dedicated register for the temperature output selection.

Name	Description	Width	Default	Address	Bit	R/W
TOUT_SEL	'1': Calibrated temperature data on the output '0': Raw temperature data on the output	1	0	9	2	R/W

Due to the System Register structure, changing the temperature data format requires several steps. The other bits of the Address 0x09 should not be changed by the user. The temperature output selection procedure is described in the following table:

Step	Command	Description
1	RSYST_09	Read the initial 32-bits data of System Register at 0x09
2	-	Modify only the bit 2 of the 32-bits data
3	WSYST_09	Write the modified 32-bits data in the System Register at 0x09

Table 20 : Temperature data format selection procedure

11.4.3 Write the temperature sensor calibration coefficients

Since the temperature sensor is not factory-calibrated, the user should perform its own calibration procedure following the instructions in section 9, to obtain O & G coefficients.

Name	Width	Address	Bit	R/W
O	12	0x04	[27:16]	R/W
G	12	0x04	[13:2]	R/W

Table 21 : Temperature sensor coefficients description

The following table presents the procedure used to write the temperature sensor calibration coefficients. Please note that the non-used bits [31:28], [15:14] and [1:0] of the registers corresponding to the temperature sensor coefficients should not be changed by the user.

Step	Command	Description
1	RSYST_04	Read the initial 32-bits data of System Register at 0x04
2	-	Modify only the corresponding bits of the 32-bits data (table 15)
3	WSYST_04	Write the modified 32-bits data in the System Register at 0x04

Table 22 : Temperature sensor coefficients SPI commands

11.4.4 Write the temperature compensation coefficients for angular rate output

If the user wants to re-calibrate the angular rate output, he should perform its own calibration procedure following the instructions in section 8, to obtain the following set of coefficients:

Name	Width	Address	Bit	R/W
SF2	16	0x2E	[31:16]	R/W
B2	16	0x2E	[15:0]	R/W
B1	30	0x2F	[29:0]	R/W
B0	30	0x30	[29:0]	R/W
SF1	30	0x31	[29:0]	R/W
SF0	30	0x32	[29:0]	R/W
TMID	20	0x33	[19:0]	R/W

Table 23 : Temperature compensation coefficients description

The following table presents all the SPI commands used to write the temperature compensation coefficients resulting from the calibration process. All these SPI frames have a 56-bit width. Please note that the non-used bits of the registers corresponding to the temperature coefficients have to be written with '0'.

Mnemonic	Command	SPI Register Address	Argument			Description
			Data (32-bits)	System Register Address	System Register Command	
WRSF2B2	0x7	0x8	SF2 B2	0x2E	0x02	Write SF2 and B2 in the System Register
WRB1	0x7	0x8	00+B1	0x2F	0x02	Write B1 in the System Register
WRB0	0x7	0x8	00+B0	0x30	0x02	Write B0 in the System Register
WRSF1	0x7	0x8	00+SF1	0x31	0x02	Write SF1 in the System Register
WRSF0	0x7	0x8	00+SF0	0x32	0x02	Write SF0 in the System Register
WRTMID	0x7	0x8	000000000000+TMID	0x33	0x02	Write TMID in the System Register

Table 24 : Temperature compensation coefficient writing commands

11.4.5 Writing in the MTP

The temperature compensation coefficients of the gyro output can be programmed up to 7 additional times. The temperature output calibration coefficients can be programmed 1 additional time. This section details the procedure used to perform this function. The MTP programming procedure consists of three major steps.

- Checking the available MTP slots status.
- Programming the new coefficients into the MTP.
- Updating the available MTP slots status.

The general commands are described in the following table:

Mnemonic	Command	SPI Register Address	Argument			Description
			Data	System Register Address	System Register Command	
RMTP_m	0x7	0xC	-	address_m	0x08	Copy the address_m 32-bit value from the OTP to the SPI register
	0x5	0x8	0x00000000	-	-	Read the copied data in the SPI Register
PMTP_m	0x7	0xC	-	address_m	0x06	Programmed the MTP

Table 25 : MTP commands

11.4.6 Checking the MTP slots value

This procedure is useful to check the available MTP slots, in other words, to see how many times the chip has been programmed before. The MTP slots number is written in the System Register and programmed in the OTP.

Name	Width	Address	Bit	R/W
MTPSLOTNB	8	0x02	[15:8]	R/W

The MTP slot number (MTPSLOTNB) reprogramming iteration is given in the following table:

Programming Iteration	Correspondence	MTP Number	
		Value	Binary
0	Blank Part	0	00000000
1	Programmed once	1	00000001
2	Programmed twice	3	00000011
3	...	7	00000111
4		15	00001111
5		31	00011111
6		63	00111111
7		127	01111111
8	Cannot be further programmed	255	11111111

Table 26 : MTPSLOTNB register coding

The procedure for checking the MTP slot value is described in the following table:

Step	Command	Description
1	RMTP_02	Read the 32-bits data of OTP at 0x02
2	-	Extract the bits [15:8] from the 32-bit data read

Table 27 : Check MTP slot value procedure

11.4.7 Programming the Coefficients

This section describes the procedure for programming the calculated coefficients (temperature compensation coefficients of the angular rate output and temperature output calibration coefficients). The programming procedure is explained hereafter:

Step	Command	Description
2	WRSF2B2	Write SF2 and B2 in the System Register
2	PMTP_2E	Program SF2 and B2
3	WRB1	Write B1 in the System Register
4	PMTP_2F	Program B1
5	WRB0	Write B0 in the System Register
6	PMTP_30	Program B0
7	WRSF1	Write SF1 in the System Register
8	PMTP_31	Program SF1
9	WRSF0	Write SF0 in the System Register
10	PMTP_32	Program SF0
11	WRTMID	Write TMID in the System Register
12	PMTP_33	Program TMID
13	RSYST_04	Read the initial 32-bits data of System Register at 0x04
14	-	Modify only the bits [27:16] and [13:2] of the 32-bits data
15	WSYST_04	Write the modified 32-bits data in the System Register at 0x04
16	PMTP	Program O and G

Table 28 : Coefficient programming commands

11.4.8 Updating the MTP slots value

This section describes how to program the updated value of the MTP slots.

If this step is not performed properly, the new compensation coefficients will not be effective.

The detailed procedure is explained in the following table:

Step	Command	Description
1	RMTP_02	Read the 32-bits data of OTP at 0x02
2	-	Extract the bits [15:8] from the 32-bit data read
3	-	Increase MTPSLOTNB according to Table 26
4	WSYST_02	Write the updated MTPSLOTNB on the system register
5	PMTP_02	Program the updated MTPSLOTNB on the OTP

Table 29 : Updating MTP slot value procedure

11.5 Device Identification

GYPRO2300 traceability information can be read from the label of GYPRO2300, as shown in the figure below.

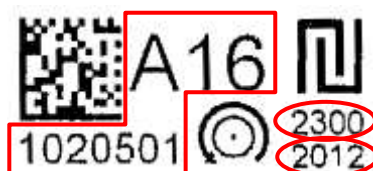

Figure 17 : Example of GYPRO2300 label

Label text	Description
1020501A16	Serial number
2300	Generic Part number
2012	Date code

The serial number is also encoded on the data matrix.

12 Document change control

Rev	Date		Change description
0.1	7-Sept-2012		Initial release
0.2	10-Oct-2012		Update specification table Add vibration tolerance power density figure
0.3	9-Nov-2012		Add Allan Variance curves Update data rate programmability Add soldering guidelines Add temperature output format selection
1.0	27-Dec-2012		Update Allan Variance, Bias and ST over temperature curves Update translation table [°/s – LSB] Update application circuit Update typical latency
1.1	11-Feb-2013		Update Application circuit Update Electrical characteristics Update SPI parameters
1.2	15-May-2014	§5 §6.1 §6.5 §7 §8.4 §10.3 §11.3.1 §11.4 §12	Update Soldering guidelines Update Mechanical characteristics Add ESD Cautions Update graphs of typical performance characteristics Update Angular rate sensor Temperature compensation procedure Add SPI recommendations Update Raw/T-Compensated gyro output Add device identification Add ordering information
2.0	1-July-2014	§4.5 §6.1 §8.3 §9.3/§9.4 §11.1 §11.2 §11.3.2 §11.3.3/11.3.7	Add GYPRO2300LD Update Key features Update ordering information Update Self-test Update Mechanical characteristics Update Angular rate sensor Temperature compensation procedure Update Temperature sensor calibration procedure Update SPI register Update Output data Update Raw/Calibrated temperature output Update Temperature sensor calibration coefficients
2.1	2-Apr-2015	§11.2.2 §11.3 §11.3.2 §11.3.4 §11.3.7	English review Update Ordering information Update Output temperature data description Update System register general command Update Data format selection procedure Update Temperature compensation coefficient writing commands Update Coefficient programming command

DATASHEET
GYPRO2300

2.2	01-Sept-2016	§2 §3 §5 §6.1 §6.5 §7 8.3 §10.1 §11.1 §11.4	Update figures Update Pin function descriptions Add part 5.2 PCB footprint Update Mechanical characteristics Update ESD Caution Add Noise density and bandwidth curves Update SF0 format Add information about DOUT state Add section on IC clock system Update procedures 11.4.4 to 11.4.7
-----	--------------	--	--